

REVISION RECORD

REV	ECN	DESCRIPTION	DRFT	DATE
-----	-----	-------------	------	------

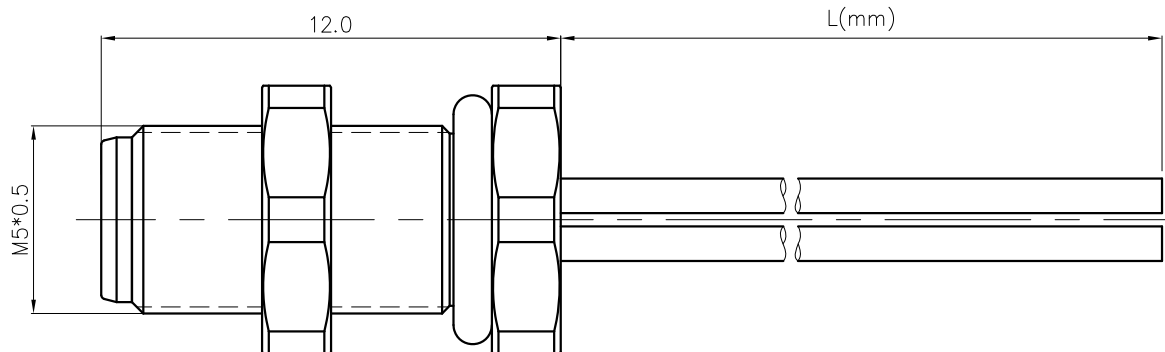
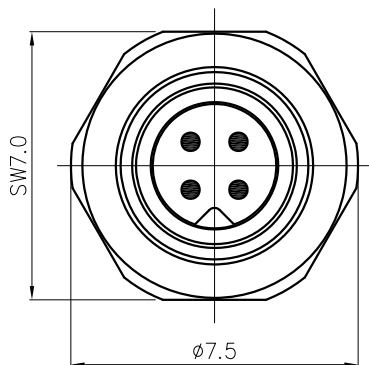

SD-M5A-XXP-MM-SF7AXX-00A(H)

Pin number: 03,04

XX: 150~1500mm
 15: 150±15mm
 30: 300±20mm
 50: 500±20mm
 A0: 1000±40mm
 A5: 1500±40mm
 Wire Length(L): 150~1500mm

NOTES:

1. Rated voltage/current : 60V / 1A
2. Withstanding voltage : 800V
3. Levels of protection: IP67
4. Wire specifications : 26AWG/0.14mm², UL1061
5. Wire connection mode: soldering
6. Operating temperature: -40°C~+85°C
7. For Panel Thickness Range : 1.0~2.0mm
8. RoHS Compliance
9. Tolerance :
 - .X ±0.25mm
 - .XX ±0.1mm
 - Angles ±1°

3pin A Coding		4pin A Coding	
Pin Assignment Front View		Pin Assignment Front View	
		4	Black
4	Black	3	Blue
3	Blue	2	White
1	Brown	1	Brown
Conn	Wire Color	Conn	Wire Color
Pin Out		Pin Out	

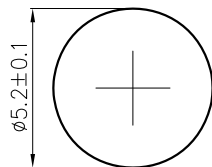

Panel cut

DETACHED LISTS	PART NO.: SDM5AXXPMMSF7AXX00AH		宁波高松电子有限公司 NINGBO DEGSON ELECTRICAL CO., LTD	
	APPD:	NAME: SD-M5A-XXP-MM-SF7AXX-00A(H)		
	CHKD:	TITLE: CUSTOMER DRAWING		
	DRFT: SQ 2019.05.11	REV	D0-1	
THIRD ANGLE PROJECTION		DRAWING NO.: XXXXXXXX-XX-CXX		SHEET 1/1
		DO NOT SCALE DRAWING		SCALE 1:1